

Wilcox
— GSE —



MAINTENANCE
STAIRS



BUILT TOUGH...
AND ENGINEERED
TO LAST!





SPECIFICATIONS

- ◆ 600LB UPPER PLATFORM CAPACITY
- ◆ HYDRAULICALLY ADJUSTABLE FROM 97" TO 134"
- ◆ NON-SLIP GRIPSTRUT OR KNURLED STAIRS AND PLATFORMS
- ◆ FRONT DOCKING BUMPER
- ◆ TUBULAR ALUMINUM CONSTRUCTION
- ◆ ADJUSTABLE TOP RAILS WITH BUMPERS
- ◆ HAND PUMP WITH DUAL MECHANICAL SAFETY LATCH
- ◆ FLOW CONTROL VALVE TO ADJUST LOWERING SPEED
- ◆ FOUR JACK LEG SUPPORTS
- ◆ HEAVY DUTY CASTERS OR WHEELS
- ◆ TOWABLE OPTION AVAILABLE
- ◆ SINGLE OPERATOR MOVABILITY

◆ SUITABLE FOR

- ◆ BOEING 737 NG 737 MAX
- ◆ AIRBUS A220 A320 A321
- ◆ EMBRAER E170 E190



WE ARE HERE TO HELP!



WILCOX GSE
550 MCGEACHIE DRIVE
MILTON, ON L9T 3Y5 CANADA



(888) 294-5269

WWW.WILCOXGSE.COM

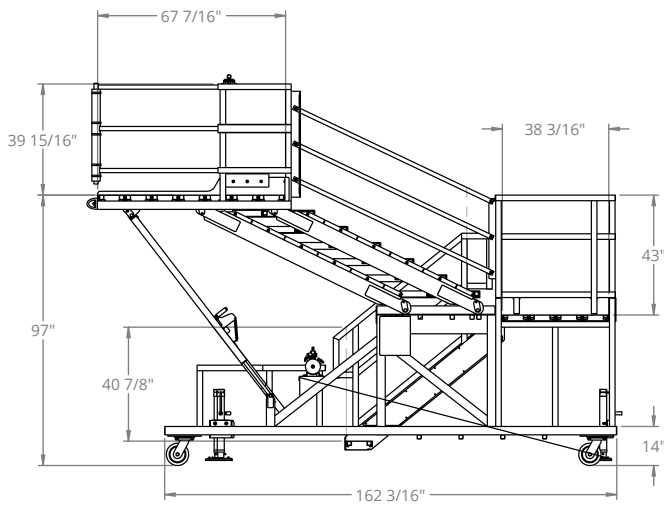

MINIMUM LEVEL

